

DDP_m

JET PUMP FOR DEEP WELLS SERIES



DDP_m-255A



DDP_m-505A



JA

JET PUMP FOR DEEP WELLS SERIES



APPLICATION AREA:

For daily use, well use, pipeline pressure, irrigation, garden and high-rise building supply.

OPERATING LIMITS:

Trans medium's PH: 6-8.5
Fluid temperature limit: 40°C
Max ambient temperature: 55°C

STRUCTURAL CHARACTERISTICS:

1. Brass impeller
2. Stainless steel shaft/carbon steel shaft
3. NSK / C&U bearing
4. Suction delivery up to 20m.
5. Insulation Class: B
6. Protection Class: IP44

DDPm

JET PUMP FOR DEEP WELLS SERIES

PERFORMANCE CHART AT $n=2900r/min$

MODEL	POWER		INLET/OUTLET	MAX.FLOW (L/min)	MAX.HEAD (m)	MAX.SUCT (m)	G.W (kg)	PACKING DIMENSION (mm)
	kW	HP						
DDPm-255A	0.55	0.75	1 1/4"/1"X1"	75	60	30	16	390*270*220
DDPm-370A	0.75	1	1 1/4"/1"X1"	85	80	40	19	390*270*220
DDPm-505A	1.1	1.5	1 1/4"/1"X1"	100	100	50	30	525*230*285
JA150	1.1	1.5	1 1/2"/1"	120	56	9	29	630*250*300
JA200	1.65	2.2	1 1/2"/1"	125	60	9	30	630*250*300
JA300	2.2	3	1 1/2"/1"	140	62	9	31	630*250*300

MODEL	DNP	DN1	DN2	DN3	DN4	De	a	a1	a2	f	f1	h	h1	l	n	n1	w	s
DDPm-255A	4"	1 1/4"	1"	1"	1"	97	91	45	142	375	515	193	94	177	184	142	100	10
DDPm-370A	4"	1 1/4"	1"	1"	1"	97	91	45	142	375	515	193	94	177	184	142	100	10
DDPm-505A	4"	1 1/4"	1"	1"	1"	97	55	45	142	384	455	255	221	255	198	145	120	10

WATER PUMP WITH INTEGRAL EJECTOR

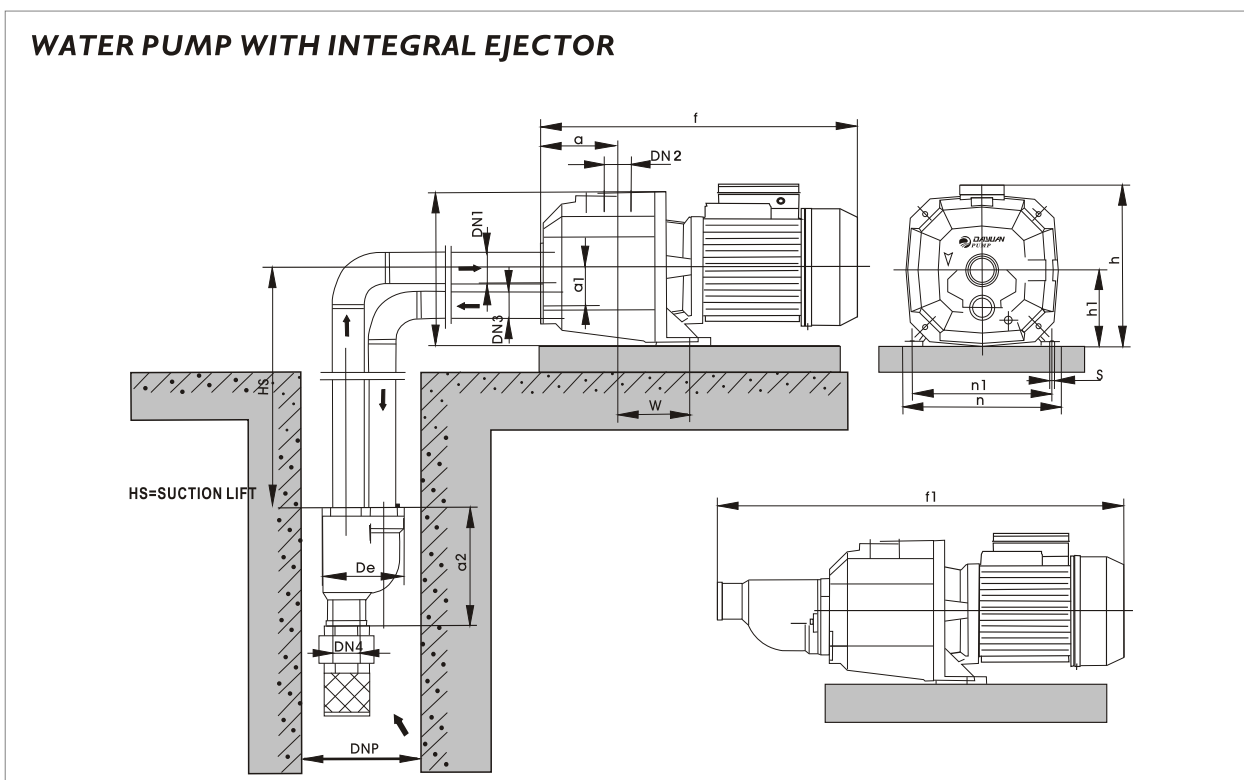

SWIMMING POOL PUMP SERIES



APPLICATION AREA:

Swimming pool and spa pool.

OPERATING LIMITS:

Trans medium's PH: 6-8.5
Fluid temperature limit: 40°C
Max ambient temperature: 75°C

STRUCTURAL CHARACTERISTICS:

1. Insulation Class: class I
2. Protection Class: IP68

SP

SWIMMING POOL PUMP SERIES

PERFORMANCE CHART AT $n=2900r/min$

MODEL	POWER		INLET/OUTLET	MAX.FLOW (L/min)	MAX.HEAD (m)	G.W (kg)	PACKING DIMENSION (mm)	
	Single phase	kW						HP
SP-180		0.25	0.3	1"X1"	60	8	4	300*150*220
SP-280		0.45	0.6	1 1/2"X1 1/2"	160	9	5.5	330*185*220
SP-370		0.45	0.6	1 1/2"X1 1/2"	160	9	7	410*185*220
SP-402		0.40	0.55	1 1/2"X1 1/2"	160	9	7	430*220*250
SP-450		0.85	1.3	1 1/2"X1 1/2"	230	12.5	10.8	540*250*370
SP-750		1.05	1.4	1 1/2"X1 1/2"	270	15	11.5	540*250*370
SP-6000		0.4	0.55	1 1/2"X1 1/2"	140	8	8	410*185*220
SP-8000		0.45	0.6	1 1/2"X1 1/2"	160	9	8	410*185*220

